

# FIT

## Food Industry Telephone

### FIT OUTDOOR INDUSTRIAL ANALOG NON-HAZARDOUS TELEPHONE

- FIT-80 - Metal Keypad/Noise Canceling Microphone Handset/Heavy Duty Coil Cord

### FEATURES and BENEFITS

- Water/dust-tight thermoplastic resin enclosure, Type 4X & IP66
- Circuit boards encapsulated in epoxy resin impervious to water and condensation
- Modified circuit board for increased volume in high noise environments
- Stainless steel faceplate
- Metal keypad covered with teleseal for additional protection
- Magnetic reed hook-switch to reduce the number of moving parts subject to wear
- Surge arrestor to prevent voltage spike damage
- Heavy duty industrial volume control handset
- Noise cancelling microphone
- Operating temperature range from -40° to +140°F (-40° to +60°C)
- Integrated mounting feet
- Receiver is hearing aid compatible
- Spring loaded door
- Easy support drill guides for top & bottom mount glands

### APPLICATIONS

Guardian's FIT-80 Food Industry Telephone was primarily designed to be the top of the line, water tight telephone to meet the high demands of the food industry. This also makes the FIT-80 ideal for use in a diverse range of other extreme moisture and corrosion applications including:

- |                              |                      |
|------------------------------|----------------------|
| Food Processing Plants       | Pulp & Paper Mills   |
| Power Generation Facilities  | Any Outdoor Location |
| Cement Plants                | Waterfront Locations |
| Waste Water Treatment Plants | Greenhouses          |
| Construction Sites           | Mines                |
| Highway Call Boxes           | and more . . .       |

### INSTALLATION and CONNECTABILITY

To provide flexibility and the potential for growth, Guardian's telephones can be easily and economically connected to any telephone network through standard wiring and parts. Voice quality is unaffected when phones are connected within 15,000 feet (~ 4,600 meters) of a main telephone switch supporting single line telephones. Maintaining safety standards may require wiring conduits or other considerations. Order the FIT-80 Food Industry Telephone separately or as part of an integrated system.

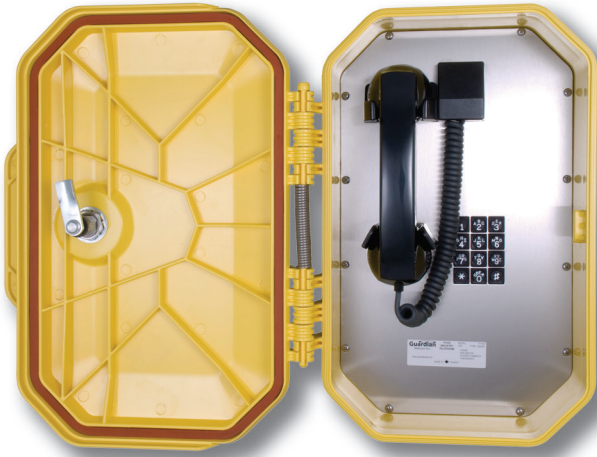

FIT-80

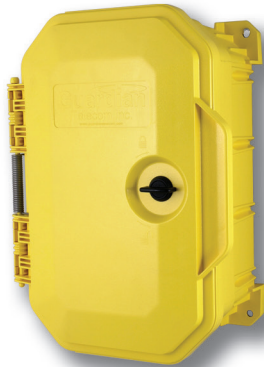

### FIT-80 TELEPHONE

Guardian's FIT-80 Food Industry Industrial Analog Telephone with stainless steel faceplate, teleseal covered metal keypad and curly handset cord offers maximum efficiency under extreme environmental conditions. The sturdy thermoplastic enclosure protects the internal circuitry against wind blown dust, rain, corrosion, splashing and high-pressure water. The FIT-80 is approved with Type 4X & IP66 ratings, making it the ideal telephone for use in wet or corrosive atmospheres such as Food Processing Plants.

### ACCESSORIES

- Ring Detect Relays & Off-Hook Relays
- External ringer
- Visual alerter



tough. trusted. true.



## OVERALL DIMENSIONS

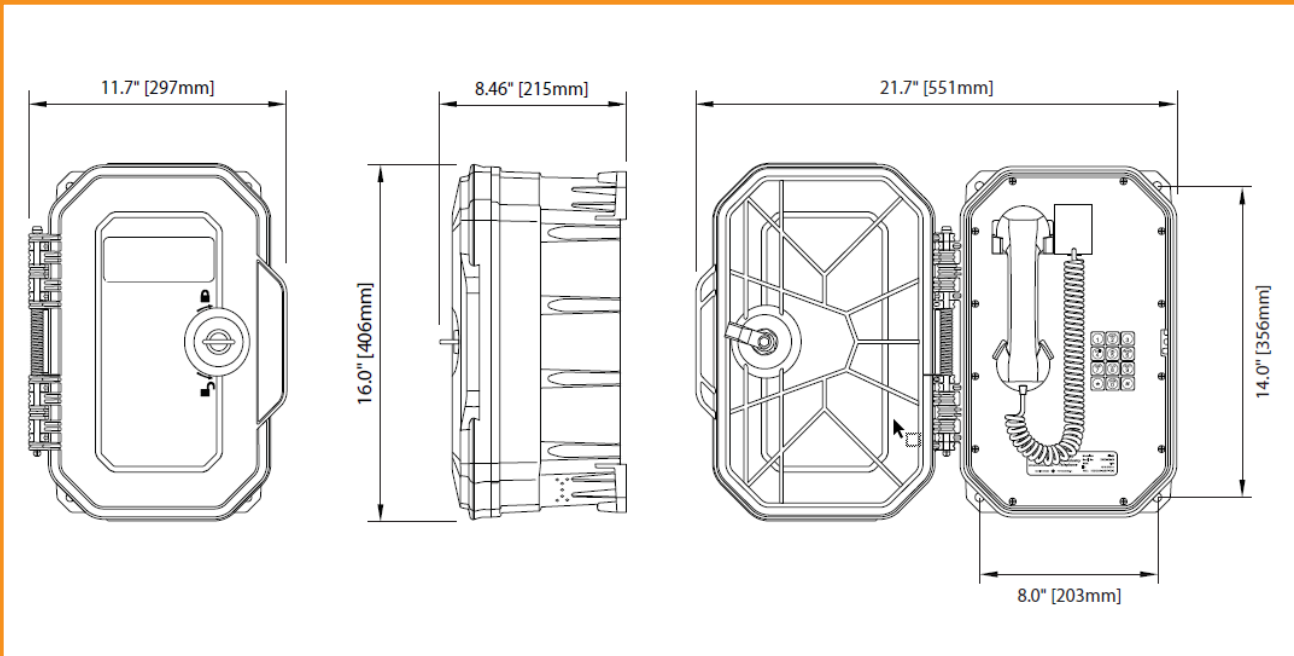

FIT-80 Food Industry Telephone

## ENGINEERING SPECIFICATIONS

### ELECTRICAL PERFORMANCE

Audio Range Frequency Response	300 - 3400 Hz
Dialing Method	DTMF or 40/60 Pulse @10 PPS
Transmit Objective Loudness Rating (TOLR)	Nominal -38 +/- 3 dB
Receiver Volume Adjustment	3 Steps Up / 2 Steps Down 8.1dB / 5.1 dB
Receiver Objective Loudness Rating (ROLR)	Nominal 39.6 +/- 3 dB
- receiver volume at maximum	31.9 +/- 3 dB
- receiver volume at minimum	45.2 +/- 3 dB
Side Tone Objective Loudness Rating (SOLR)	Nominal -3.1 +/- 4 dB
- receiver volume at maximum	- 10.5 dB
- receiver volume at minimum	2.6 dB
Ringer Output	>75 dB
FCC Ringer Equivalence	0.8 B
Set Impedance	600 Ohms Nominal
Maximum Loop	15Kft (~4,600m) of 22 AWG Wire

### ELECTRICAL REQUIREMENTS

Ringer Sensitivity	40 -100 V, 16 - 25 Hz
Line Voltage	24 - 56 VDC
Loop Current	20 - 120 mA
Connection Method	Surge Arrestor
Fuse	1/4 AMP 250 Volt 3AG Fast Blow

### ENVIRONMENTAL

Water/Dust Tight Enclosure	Type 4X & IP66
Storage Temperature	-58° to +176°F (-50° to +80°C)
Humidity	0 - 95% RH Non-Condensing
Dust & Corrosion Resistant	Full Gasket Faceplate

### MECHANICAL SPECIFICATIONS

Hook Switch (Cradle Switch) Life	>1 000 000 Operations
Body Construction	Thermoplastic Resin
Face Plate	Stainless Steel
Net Weight	13.0 lbs ( 5.9 kg)
Shipping Weight	15.0 lbs ( 6.8 kg)
Shipping Dimensions ( L x W x D )	20.0" x 15.0" x 12.0" ( 508 x 381 x 305 mm)
Hand Set Construction	High Impact Polycarbonate
Mounting	Vertical Wall
Microphone	Noise Canceling Electret
Receiver	Hearing Aid Compatible
Hardware Material	Stainless Steel
Connection Fittings	Up to 4 Drill Guides for Gland Support

### ORDERING INFORMATION

Warranty: Three years parts and labor

Order No.	Description
P5307	FIT-80 Metal Keypad/Noise Canceling Microphone Handset/Curly Cord

Options	Description
LCK-WTE	Locking Door
VR-WTE	Vandal Resistant Faceplate Screws

Distributed by:



GUARDIAN TELECOM, a division of CIRCA ENTERPRISES INC.  
 Calgary, Alberta, Canada  
 Telephone: 403 258-3100 Facsimile: 403 253-4967  
 1-800-363-8010 (North America)  
 info@guardiantelecom.com | www.guardiantelecom.com